

Silencers

Shape: Rectangular
Type: Rectangular, Fiberglass

General Construction

Outer Casing: Galvanized, 22 Gauge
Perforated: Galvanized, 26 Gauge
Fill Material: Fiberglass



Ratings and Listings

Max. Pressure: 8 in.w.g.
Flame Spread: 25
Smoke Developed: 50

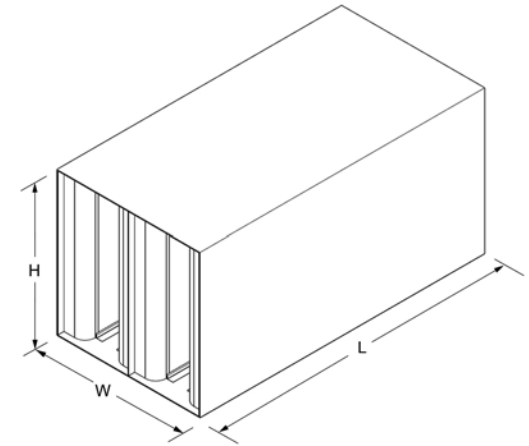

Details

Line Item	Tag	Model	Qty	Dimensions (in)		Sections (in)		Weight (lbs)	Airflow (cfm)	Velocity (fpm)	PD (in. wg.)	Dynamic Insertion Loss (dB)								Self Generated Noise (dB)							
				W x H	L	Qty	W x H					63	125	250	500	1K	2K	4K	8K	63	125	250	500	1K	2K	4K	8K
1		RFN 24J	1	24 x 20	36	1	24 x 20	58	+1950	+585	0.09	4	9	16	24	22	17	14	12	45	48	38	37	42	39	30	19
2		RFN 24I	1	24 x 16	36	1	24 x 16	49	+1600	+600	0.09	5	7	14	23	21	17	15	14	59	46	36	33	34	30	20	18

Unless otherwise indicated, dimensions shown are in **INCHES**.

Note: The above information is based on tests conducted in accordance with ASTM E477-13 and do NOT include system effects for silencers installed immediately before the elbows, transitions, at the top of the discharge of the system, or within a duct. These system effects can increase the silencer pressure loss by several times that shown above. Allowances to compensate for such conditions must be included when calculating pressure loss through the silencer.