

POWER & EFFICIENCY

| | | | |
|-----------------------------|--|--|-----------------------|
| INPUT POWER OPTIONS | AC 1PH 200-240V 60Hz AC 3PH 200-240V 60Hz AC 3PH 380-480V 60Hz | | |
| MAXIMUM RATED CURRENT (amp) | 5.4-4.5 A | | 2.8-2.4 A 2.2-1.9 A |
| POWER (hp) | 3/4 hp | | |
| MAXIMUM SPEED (RPM) | 105 RPM | | |
| EFFICIENCY | 135,000 CFM/HP | | |

DIMENSIONS & WEIGHT

| | |
|--------------|----------------|
| FAN DIAMETER | 14 ft |
| FAN WEIGHT | 168 lb (76 kg) |

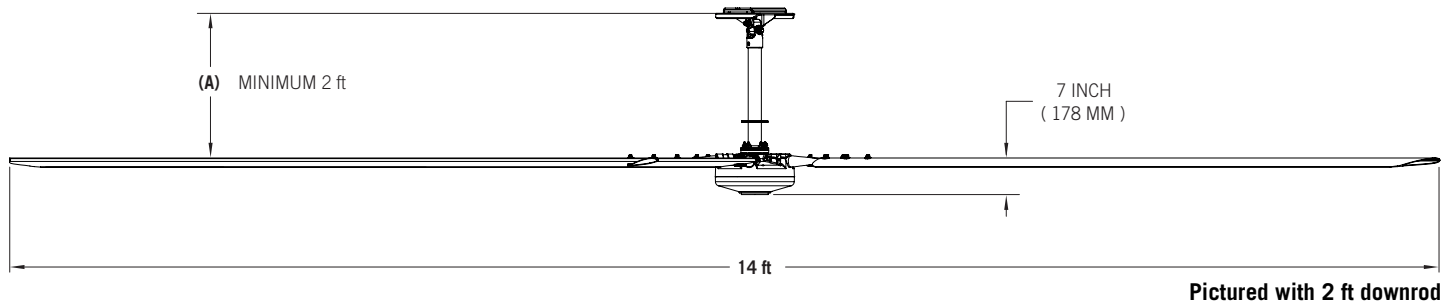

MOUNTING & SAFETY

| | |
|------------------|--|
| MOUNTING OPTIONS | I-beam Glulam |
| DOWNROD (A) | Downrods available in 1 ft increments: 2 ft min., 10 ft max. Downrod length must be specified at time of order. |
| SAFETY FEATURES | Fan Retention System Airfoil Retention System Fire relay |

IN THE BOX

| | |
|----------|--|
| INCLUDED | Fan I-beam mount with pre-wired downrod Control panel Install manual Mounting hardware kit Communication Kit Guy wire kit |
| OPTIONAL | Additional cable lengths Touchscreen (5 in) Glulam brackets |

WARRANTY & CERTIFICATIONS

| | |
|-----------------------|--|
| CERTIFICATIONS | ETL/Intertek-certified to ANSI/UL 507 and CSA C22.2 No. 113 in North America |
| WARRANTY ¹ | 15-year, Non-Prorated Warranty |

¹See complete warranty for details.



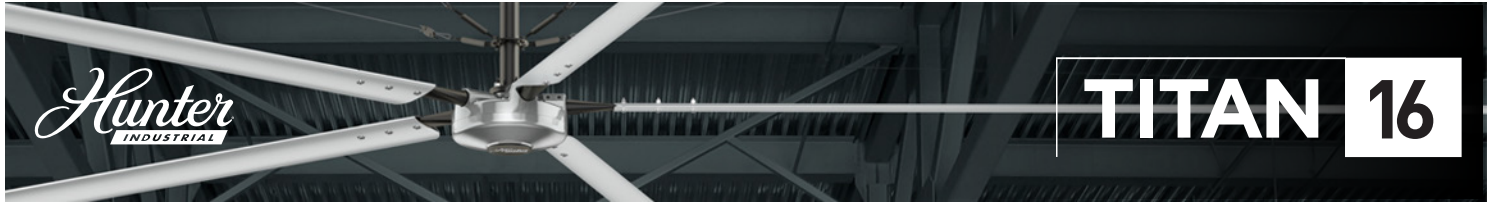

POWER & EFFICIENCY

| | | | |
|-----------------------------|--|--|-----------------------|
| INPUT POWER OPTIONS | AC 1PH 200-240V 60Hz AC 3PH 200-240V 60Hz AC 3PH 380-480V 60Hz | | |
| MAXIMUM RATED CURRENT (amp) | 7.2-6 A | | 3.8-3.2 A 3.1-2.6 A |
| POWER (hp) | 1 hp | | |
| MAXIMUM SPEED (RPM) | 102 RPM | | |
| EFFICIENCY | 185,000 CFM/HP | | |

DIMENSIONS & WEIGHT

| | |
|--------------|----------------|
| FAN DIAMETER | 16 ft |
| FAN WEIGHT | 175 lb (79 kg) |

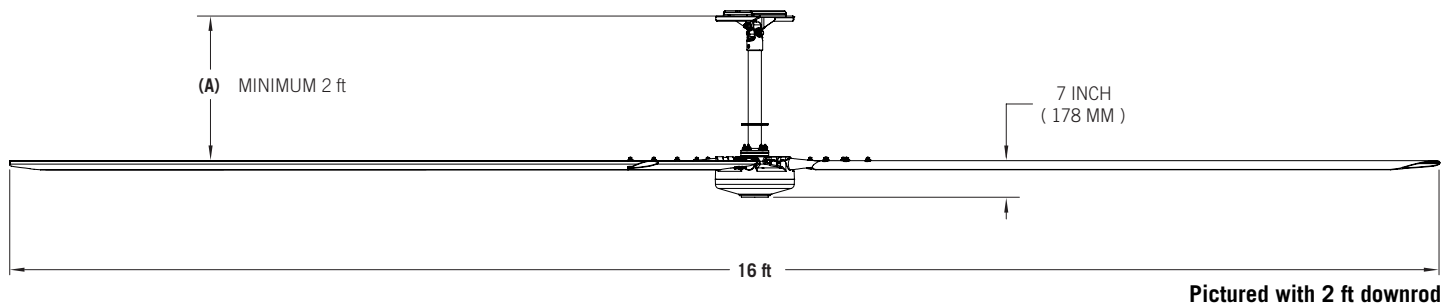

MOUNTING & SAFETY

| | |
|------------------|--|
| MOUNTING OPTIONS | I-beam Glulam |
| DOWNROD (A) | Downrods available in 1 ft increments: 2 ft min., 10 ft max. Downrod length must be specified at time of order. |
| SAFETY FEATURES | Fan Retention System Airfoil Retention System Fire relay |

IN THE BOX

| | |
|----------|--|
| INCLUDED | Fan I-beam mount with pre-wired downrod Control panel Install manual Mounting hardware kit Communication Kit Guy wire kit |
| OPTIONAL | Additional cable lengths Touchscreen (5 in) Glulam brackets |

WARRANTY & CERTIFICATIONS

| | |
|-----------------------|---|
| CERTIFICATIONS | ETL/Intertek-certified to ANSI/UL 507 and CSA C22.2 No. 113 in North America |
| WARRANTY ¹ | 15-year, Non-Prorated Warranty |

¹See complete warranty for details.



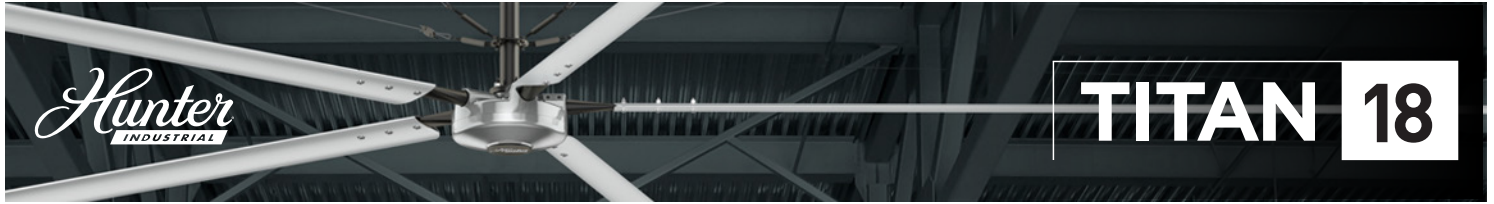

POWER & EFFICIENCY

| | | | |
|-----------------------------|--|--|-----------------------|
| INPUT POWER OPTIONS | AC 1PH 200-240V 60Hz AC 3PH 200-240V 60Hz AC 3PH 380-480V 60Hz | | |
| MAXIMUM RATED CURRENT (amp) | 7.8-6.5 A | | 4.1-3.4 A 3.3-2.7 A |
| POWER (hp) | 1 hp | | |
| MAXIMUM SPEED (RPM) | 95 RPM | | |
| EFFICIENCY | 215,000 CFM/HP | | |

DIMENSIONS & WEIGHT

| | |
|--------------|----------------|
| FAN DIAMETER | 18 ft |
| FAN WEIGHT | 183 lb (83 kg) |

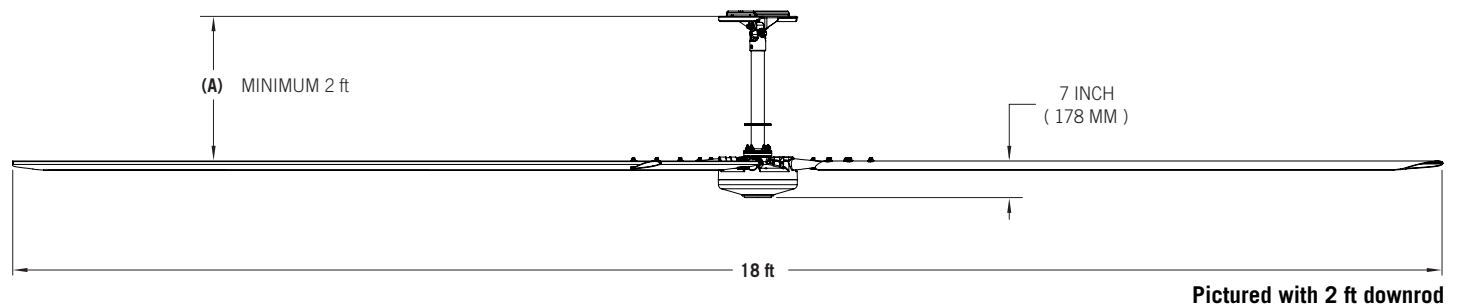

MOUNTING & SAFETY

| | |
|------------------|--|
| MOUNTING OPTIONS | I-beam Glulam |
| DOWNROD (A) | Downrods available in 1 ft increments: 2 ft min., 10 ft max. Downrod length must be specified at time of order. |
| SAFETY FEATURES | Fan Retention System Airfoil Retention System Fire relay |

IN THE BOX

| | |
|----------|--|
| INCLUDED | Fan I-beam mount with pre-wired downrod Control panel Install manual Mounting hardware kit Communication Kit Guy wire kit |
| OPTIONAL | Additional cable lengths Touchscreen (5 in) Glulam brackets |

WARRANTY & CERTIFICATIONS

| | |
|-----------------------|--|
| CERTIFICATIONS | ETL/Intertek-certified to ANSI/UL 507 and CSA C22.2 No. 113 in North America |
| WARRANTY ¹ | 15-year, Non-Prorated Warranty |

¹See complete warranty for details.

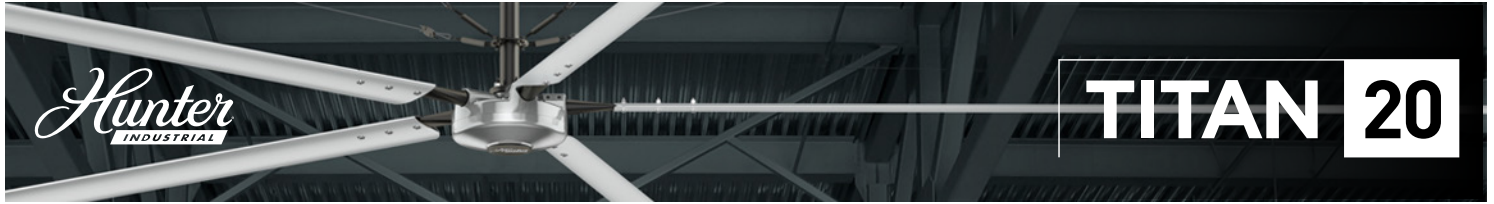

POWER & EFFICIENCY

| | | | |
|-----------------------------|--|--|---------------------|
| INPUT POWER OPTIONS | AC 1PH 200-240V 60Hz AC 3PH 200-240V 60Hz AC 3PH 380-480V 60Hz | | |
| MAXIMUM RATED CURRENT (amp) | 7.2-6 A | | 4-3.3 A 3.0-2.5 A |
| POWER (hp) | 1 hp | | |
| MAXIMUM SPEED (RPM) | 82 RPM | | |
| EFFICIENCY | 255,000 CFM/HP | | |

DIMENSIONS & WEIGHT

| | |
|--------------|----------------|
| FAN DIAMETER | 20 ft |
| FAN WEIGHT | 190 lb (86 kg) |

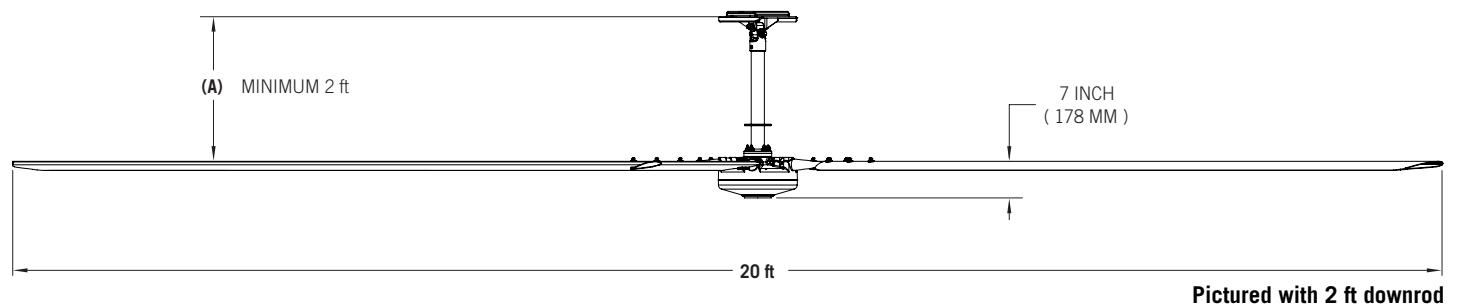

MOUNTING & SAFETY

| | |
|------------------|--|
| MOUNTING OPTIONS | I-beam Glulam |
| DOWNROD (A) | Downrods available in 1 ft increments: 2 ft min., 10 ft max. Downrod length must be specified at time of order. |
| SAFETY FEATURES | Fan Retention System Airfoil Retention System Fire relay |

IN THE BOX

| | |
|----------|--|
| INCLUDED | Fan I-beam mount with pre-wired downrod Control panel Install manual Mounting hardware kit Communication Kit Guy wire kit |
| OPTIONAL | Additional cable lengths Touchscreen (5 in) Glulam brackets |

WARRANTY & CERTIFICATIONS

| | |
|-----------------------|--|
| CERTIFICATIONS | ETL/Intertek-certified to ANSI/UL 507 and CSA C22.2 No. 113 in North America |
| WARRANTY ¹ | 15-year, Non-Prorated Warranty |

¹See complete warranty for details.



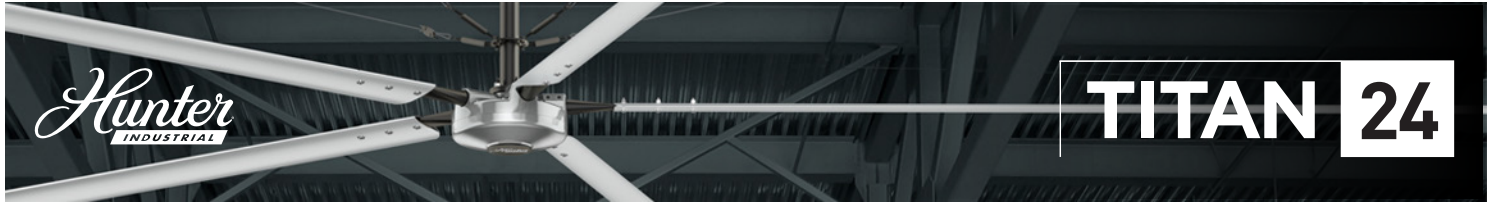

POWER & EFFICIENCY

| | | | |
|-----------------------------|--|--|-----------------------|
| INPUT POWER OPTIONS | AC 1PH 200-240V 60Hz AC 3PH 200-240V 60Hz AC 3PH 380-480V 60Hz | | |
| MAXIMUM RATED CURRENT (amp) | 8.2-6.8 A | | 4.3-3.6 A 3.2-2.7 A |
| POWER (hp) | 1 hp | | |
| MAXIMUM SPEED (RPM) | 70 RPM | | |
| EFFICIENCY | 325,000 CFM/HP | | |

DIMENSIONS & WEIGHT

| | |
|--------------|---------------|
| FAN DIAMETER | 24 ft |
| FAN WEIGHT | 204lb (93 kg) |

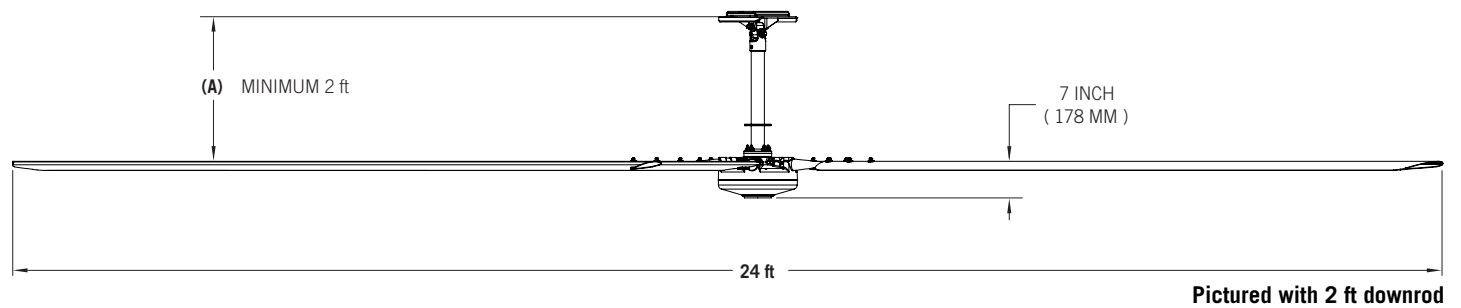

MOUNTING & SAFETY

| | |
|------------------|--|
| MOUNTING OPTIONS | I-beam Glulam |
| DOWNROD (A) | Downrods available in 1 ft increments: 2 ft min., 10 ft max. Downrod length must be specified at time of order. |
| SAFETY FEATURES | Fan Retention System Airfoil Retention System Fire relay |

IN THE BOX

| | |
|----------|--|
| INCLUDED | Fan I-beam mount with pre-wired downrod Control panel Install manual Mounting hardware kit Communication Kit Guy wire kit |
| OPTIONAL | Additional cable lengths Touchscreen (5 in) Glulam brackets |

WARRANTY & CERTIFICATIONS

| | |
|-----------------------|--|
| CERTIFICATIONS | ETL/Intertek-certified to ANSI/UL 507 and CSA C22.2 No. 113 in North America |
| WARRANTY ¹ | 15-year, Non-Prorated Warranty |

¹See complete warranty for details.

